



BE1-11F FEEDER PROTECTION SYSTEM

The BE1-11F is a multifunction numeric relay that provides three phase, ground, and negative sequence directional or non-directional overcurrent protection with four shot recloser, forward or reverse power protection, breaker failure, over/underfrequency, over/undervoltage and overexcitation protection, sync check, breaker monitoring and control, sequence-of-events recording, fault reporting, rate-of-change frequency, and metering functions, all in an integrated system.

ADVANTAGES

- Each overcurrent element can be individually set for forward or reverse directional or non-directional control for maximum flexibility in any application.
- Includes distance to the fault to aid in timely fault location and service restoration.
- BESTlogic+ provides the user with complete flexibility in configuring a protection and control system. User programmable variable and switch names make these relays completely self documenting.
- Large high-contrast programmable 128x64 LCD display allows the relay to replace local indication and control functions, such as metering, alarm annunciation, and control switches.
- Four "Table Lookup" time curves create custom curve shapes using 2-40 points
- Three independent communication ports with protocol support allows integration with distributed control systems.
- RS-485 and copper Ethernet communications, Modbus™, and DNP3.0 protocols
- Web page and user-selectable email triggers for remote alarm reporting
- High-speed BESTCOMSPPlus user interface via USB
- Power Quality reporting
- Non-volatile expanded event memory
- Includes Real Time Clock with 8 hour capacitor ride through and battery backup.
- Available in fully drawout half rack case.

WINDOWS® SOFTWARE

Interface for setting and communicating with Basler protection products
Request BESTCOMSPPlus for BE1-11

ADDITIONAL INFORMATION

INSTRUCTION MANUAL

Request publication 9424200990

MODBUS™ INSTRUCTION MANUAL

Request publication 9424200991

DNP 3.0 INSTRUCTION MANUAL

Request publication 9424200992

DEVICE FUNCTIONS

25	27	32 Option	43
47	50	51	59
60	62	67	BF
79	81	86	101
Modbus Option	Modbus TCP Option	DNP	BESTCOMS Ethernet Option

FEATURES

Pages 2 and 3

APPLICATIONS

Page 3

FUNCTIONAL DESCRIPTION

Page 4 - 6

SPECIFICATIONS

Pages 7 - 9

ORDERING INFORMATION

Page 12



FEATURES

PROTECTION

- Instantaneous Phase, Neutral, and Negative Sequence Overcurrent elements include a settable time delay: 50TP, 50TN, 50TQ
- Phase, Neutral, and Negative Sequence Time Overcurrent elements: 51P, 51N, 51Q
- Each overcurrent element can have directional control (67P, 67N, 67Q). Directional control is by Positive, Negative, Zero Sequence Voltage (670V) and Zero Sequence Current (670I) polarization.
- All U.S. and IEC timing curves plus user definable curve
- Transient overreach and overtravel are minimized for overcurrent elements
- Separate ground current input provides ground overcurrent protection and/or zero sequence current polarization.
- Phase Undervoltage and Overvoltage elements: 27P, 59P. Elements use a 1 of 3, 2 of 3, or 3 of 3 logic, and monitor either line-line or line-ground voltages.
- Forward or Reverse Power: 32
- Auxiliary Undervoltage and Overvoltage elements: 27X, 59X. Elements monitor either fundamental or third harmonic on the 4th VT input, or fundamental phase residual, 3V0, of the phase inputs.
- Negative Sequence Overvoltage element: 47
- Over/Under Frequency elements: 81
- Each 81 element can be assigned to monitor 3 phase VT input (VP) or Auxiliary voltage input (Vx).
- Breaker Failure protection function: BF
- Eight general purpose logic timers: 62
- Programmable Logic using BESTlogic+
- Four protection setting groups with external or automatic (cold load pickup, load, unbalance, recloser shot) selection modes
- Sync check with dead line/dead bus voltage monitor logic, 25, 25VM
- Fuse loss detection protects against false trip due to loss of voltage sensing: 60FL.

CONTROL

- Four shot recloser (79) with zone sequence coordination and sequence controlled protective element blocking functions
- Virtual breaker control switch—controllable from both HMI and com. ports: 101
- Four virtual selector switches—controllable from both HMI and com. ports: 43
- Virtual lockout latches: 86. Status is stored in EEPROM.
- Communication port control of 101 and #43 switches allows for SCADA control of relay and breaker.

INSTRUMENTATION

- Real time A, B, C phase current, voltage, and frequency and derived neutral and negative sequence current and voltage
- Real Time per phase and 3 phase Watts, Vars, and 3 phase Power Factor

REPORTS

- Current demands for phase, neutral, and negative sequence currents, and forward and reverse Watts and Vars—magnitudes and time stamps are recorded for today's peak, yesterday's peak, and peak since reset
- 4000 point log of demand readings
- kWh and kVarh, forward and reverse
- Breaker operations counter and contact interruption duty

FAULT RECORDING

- 1028 event sequence of events report with I/O and alarm sub-reports
- Fault Reporting; 1 or 2 oscillography records perfault report
- 16 fault summary reports; All Fault Summary Records saved to non-volatile memory
- Total number of oscillography records settable from 6 to 16
- Total of 240 cycles oscillography memory @ 32 samples/cycle
- COMTRADE format
- Load compensated distance to fault

COMMUNICATION PORTS

- Three independent general purpose communication ports and available protocols
 - Front USB-B: BESTCOMSPPlus
 - Rear RS-485: Modbus™, DNP® 3.0
 - Rear Ethernet: BESTNetPlus, BESTCOMSPPlus, Modbus™, and DNP® 3.0 protocols
- IRIG-B time sync (unmodulated)

SELF TEST AND ALARM FUNCTIONS

- Relay fail, major alarm, and minor alarm LEDs, and fail-safe alarm output contact (closed or open)
See style chart, page 12, for ordering information
- Extensive internal diagnostics monitor all internal functions of the relay.
- More than 20 additional alarm points—programmable for major or minor priority
Including:
 - Phase current, and forward and reverse watt and var demand alarm
 - Neutral and negative sequence unbalance demand
 - Three breaker alarm points programmable for slow trip, interruption duty threshold, or operations counter
 - Trip circuit voltage and continuity monitor
 - Close circuit monitor via BESTlogic+

PROGRAMMABLE I/O

- Four programmable inputs
- Five programmable outputs and one dedicated programmable alarm output

FEATURES, continued

HARDWARE FEATURES

- Case configuration - H1: half rack
- Active CT technology for low burden and increased dynamic range
- Flash Memory for upgrading embedded programming
- Real Time Clock with 8 hour capacitor ride through and battery backup
- Integral HMI with 128x64 character display
- Wide range ac/dc power supply options provide long holdup time to ride through dips on ac power source. 100 ms with 4 output relays energized, upon complete loss of source. Starting voltage 125Vac for Option 1 (48/125Vac/dc) and 250Vac for Option 2 (125/250Vac/dc).

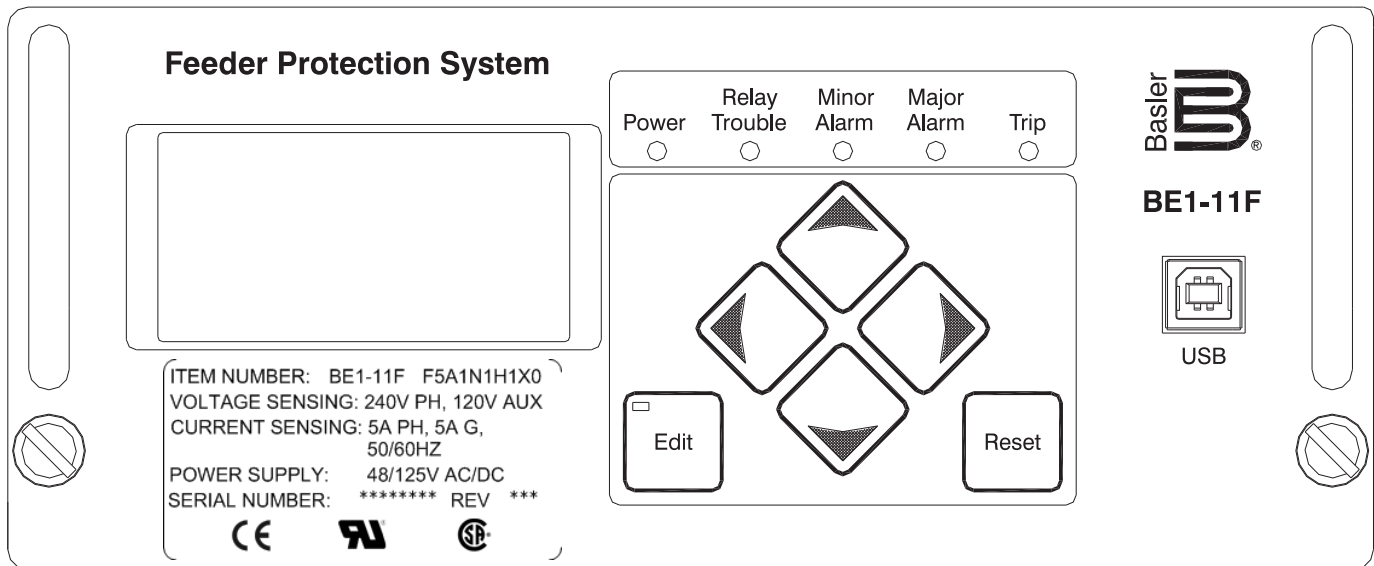

Figure 1 - Advanced HMI (Human Machine Interface)

APPLICATIONS

The BE1-11F Multifunction Protection System provides three phase, ground, and negative sequence overcurrent, voltage and frequency protection. The BE1-11F is intended for use in any application requiring directional or non-directional overcurrent protection. Its unique capabilities make it ideally suited for applications with the following requirements:

- Applications that require low burden to extend the linear range of CTs.
- Applications that require the flexibility provided by wide setting ranges, multiple setting groups, and multiple coordination curves in one unit.
- Applications that require the economy and space savings provided by a multifunction, multiphase unit. This one unit can provide all of the protection, control, metering, and local and remote indication functions required for typical applications.
- Applications that require directional control and fault locating.
- Applications that require communications and protocol support.
- Applications where the capabilities of a numeric multifunction relay are required.
- Applications where the small size and limited behind-panel projection facilitates modernizing protection and control systems in existing equipment.

FUNCTIONAL DESCRIPTION

The BE1-11F is a multifunction numeric relay that provides a comprehensive mix of protective, control, and metering functions in an integrated package. Additional features included in this relay, such as forward/reverse power (32), synch check (25), over and undervoltage (27/59), and over and underfrequency (81O/U/ROC) make this system suitable for applications including feeder or bus protection, as well as load shedding.

32 samples per cycle digital signal processing with frequency compensation extracts the fundamental component for high accuracy with distorted waveforms and at off-nominal frequency operation.

The unit has one set of three phase current and voltage sensing inputs to provide all common protective functions for substation and feeder applications. The voltage sensing circuits automatically configure themselves internally for 1 phase, 3 phase 3 wire, or 3 phase 4 wire VT circuits.

The BE1-11F also includes an independent ground current input, typically used for application with a separate ground CT such as a flux balancing window CT, or to provide ground backup protection for the neutral or tertiary of a transformer.

A fourth Auxiliary Voltage (Vx) input also is available. This voltage input can be connected to line side potential for sync check (25) and dead line (25VM) closing supervision, or to a ground sensing VT connection for ground fault protection on the delta side of a cogeneration intertie transformer.

All overcurrent elements can independently be set for forward, reverse, or nondirectional control. Directional control is obtained by positive, negative, and zero

sequence directional elements. The zero sequence current polarized element uses the optional independent ground input for its polarization signal. The zero sequence voltage polarized element requires that the VT connection be 4W. The positive sequence directional element has memory voltage to provide reliable directional control for close in balanced three phase faults.

Tripping by voltage dependent functions 27, 59, 32 will be blocked if a sensed voltage is lost (60FL).

The target reporting function in the BE1-11F automatically adapts the targets as appropriate. For example, if the 150TP and the 51P functions are set for directional control, they post targets for an A phase fault as "167A" for directional instantaneous trip or "67TA" for directional time trip respectively.

Three independent communications ports, along with built-in support for Modbus and other common protocols, provide easy access to integrating the protection, control, metering, and status monitoring functions into a substation automation system. A standard IRIG-B port provides time synchronization from an external GPS clock.

Real time metering provides Watt, Watt-hour, VAR, VARhour, Voltage, Amp, and unbalance loading telemetry for the protected equipment. Contact sensing inputs and alarm monitoring functions provide real time status information. Remote control is provided by virtual control and selector switches with select-before-operate control of programmable outputs.

Figure 2 shows typical external connections, Figure 3 illustrates the functionality contained within this device, and Figure 5 shows rear panel connections.

FUNCTIONAL DESCRIPTION, continued

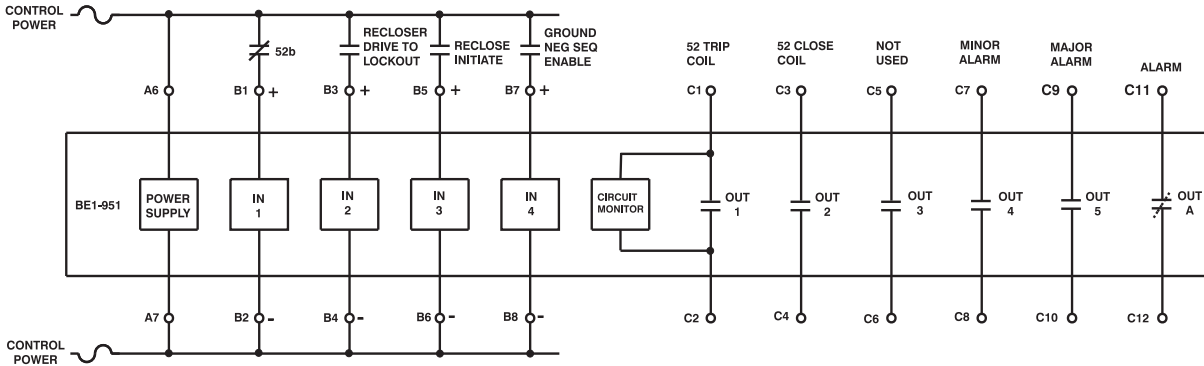

NOTES:

- Connections shown are for use with preprogrammed logic scheme OC-W-79. OC-W-79 provides overcurrent protection with reclosing capabilities. All inputs and outputs are fully programmable using BESTlogic.

Figure 2 - Typical External Connections

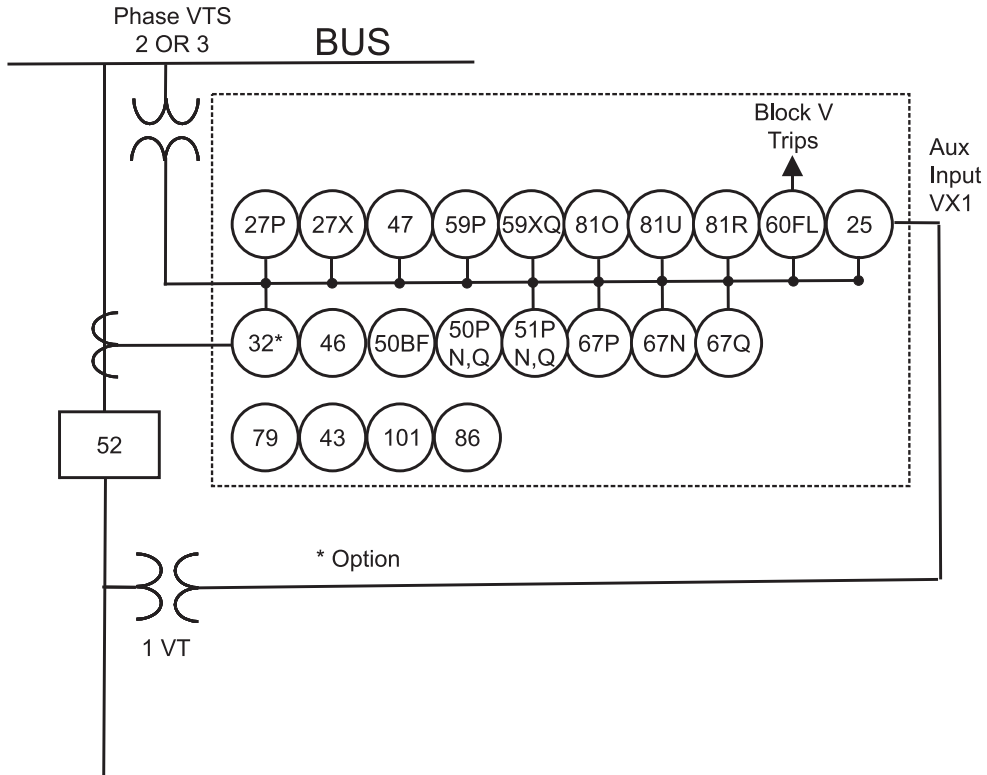

Figure 3 - BE1-11F Feeder Application

FUNCTIONAL DESCRIPTION, continued

BESTlogic+

BESTlogic+ programmable logic provides the user with high flexibility in configuring a protection and control system.

Each of the protection and control functions in the BE1-11F is implemented as an independent function block that is equivalent to its single function, discrete device counterpart. Each independent function block has all the inputs and outputs that the discrete component counterpart might have. Figure 4 shows a sample BESTlogic+ screen available in the BE1-11F. Programming BESTlogic+ is equivalent to choosing the functional devices required by your protection and control scheme and drawing schematic diagrams to connect the inputs and outputs to obtain the desired operational logic.

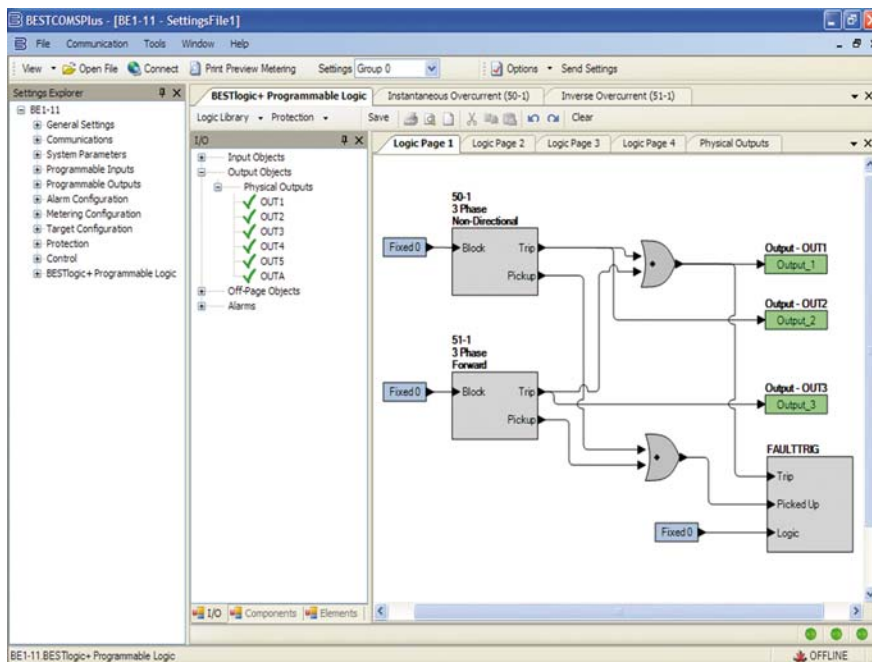

Figure 4 - BESTlogic+ Programmable Logic, Sample Screen

The BE1-11F relay can store, as user settings, one user programmable, custom logic scheme. To save time, several preprogrammed logic schemes also are provided. Any of the preprogrammed schemes may be copied into the logic settings without making any additional BESTlogic+ settings.

BESTlogic+ provides the protection engineer with the flexibility to set up this powerful multifunction system with the same freedom that was once enjoyed with single function, discrete devices. It is no longer necessary to compromise your standard protection and operating practices to deal with the limitations in programmability of previous multifunction devices. In addition, these advanced logic features have been added: Edge triggers, XOR gates, logic timers, counters, and latches.

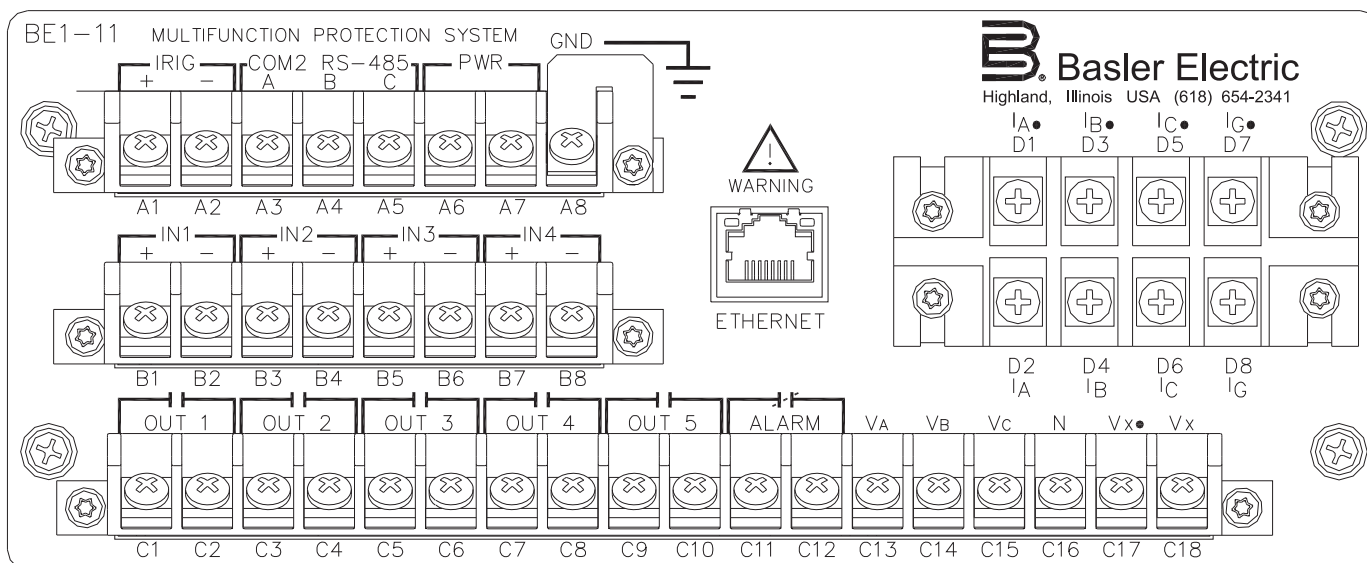

Figure 5 - BE1-11F H1 Rear Panel Connections (shown with optional Ethernet port)

GENERAL SPECIFICATIONS

5 Amp CURRENT INPUTS

Continuous rating:	20A
One Sec. Rating:	400A
Saturation limit:	150A
Burden:	<10milliohms

1 Amp CURRENT INPUTS

Continuous rating:	4A
One Sec. rating:	250A
Saturation limit:	30A
Burden:	<22milliohms

PHASE AC VOLTAGE INPUTS

Continuous:	300V, Line to Line
One Sec. rating:	600V, Line to Neutral
Burden:	Less than 1VA @ 300Vac

AUXILIARY AC VOLTAGE INPUT

Continuous:	150V
One Sec. rating:	600V
Burden:	Less than 1VA @ 150Vac

A/D CONVERTER

Sampling Rate:	32/cycle, adjusted to input frequency 10-75Hz
----------------	---

POWER SUPPLY

Option 1: 48/125Vac/dc	DC range 35 - 150V AC range 55 - 135V
Option 2: 125/250Vac/dc	DC range 90 - 300V AC range 90 - 270V
Option 3: 24Vdc	DC range 17 - 32V (down to 8V for momentary dips)
Burden:	10 Watts continuous, 12 Watts maximum with all outputs energized

TRIP CONTACTS

Make and carry:	30A (0.2sec)
Continuous:	7A
Break:	0.3A DC (L/R=0.04)

CONTROL INPUTS

Wetting voltage range:

Power Supply Option	Low Range		High Range	
	Turn-on Voltage Range	Burden	Turn-on Voltage Range	Burden
1) 48/125Vac/Vdc	26-38V	123.76k ohms	69-100V	66.49k ohms
2) 125/250Vac/Vdc	69-100V	53.65k ohms	138-200V	22.15k ohms
3) 24Vdc	5-8Vdc	6.15k ohms	N/A	N/A

Control inputs recognize both DC and AC voltages.

COMMUNICATION PORTS

Response time:	<100mSec for metering and control functions
Baud rate:	300 - 19200

ELECTRICAL ENVIRONMENT

- IEEE C37.90-1989 Standard for Relays and Relay Systems Associated with Electric Power Apparatus
- IEC 255-5 Insulation Test for Electrical Relays Impulse and Dielectric Strength (2000Vac at 50/60Hz)
- IEEE C37.90.1-1989 Standard Surge Withstand Capability Tests for Relays and Relay Systems Associated with Electric Power Apparatus
- IEC 255-22-1 1MHz Burst Disturbance Tests for Electrical Disturbance Tests for Measuring Relays and Protection Equipment
- EN 61000-4-4 Electrical Fast Transient/Burst Immunity Test
- EN 61000-4-3 Radiated, Radio-frequency, Electro-magnetic Field Immunity Test
- Type tested using a 5-Watt, hand-held transceiver in the ranges of 144 and 440MHz with the antenna placed within 6 inches of the relay.
- IEEE C37.90.3 (Jan. 01) Draft Standard Electrostatic Discharge Tests for Protective Relays
- EN 61000-4-2 Electrostatic Discharge Immunity Test

MECHANICAL ENVIRONMENT

- Operating temperature range: -40°C* to 70°C (-40°F to 158°F)
*LCD Display is inoperative below -20°C.
- Storage temperature range: -40°C to 70°C (-40°F to 158°F)
- Humidity: Qualified to IEC 68-2-38, 1st Edition 1974, Basic Environmental Test Procedures, Part 2: Test Z/AD: Composite Temperature Humidity Cyclic Test
- Qualified to IEC 255-21-1 (Class 1) Vibration Tests for Electrical Relays
- Qualified to IEC 255-21-2 (Class 1) Shock and Bump Tests for Electrical Relays

CASE SIZE

10.50"W x 3.47"H x 9.10"D with mounting flanges
(8.5"W without mounting flanges)

SHIPPING WEIGHT

Approx. 10 pounds (4.54 kg)

WARRANTY

7 years

PERFORMANCE SPECIFICATIONS

INSTANTANEOUS OVERCURRENT WITH SETTABLE DELAY (50TP, 50TN, 50TQ)

Pickup:	5A CT	0.5 - 150.0A
	1A CT	0.1 - 30.0A
PU time with TD=	0.000 Sec	
	2 cyc for P, N & G @ 5 x PU	
	3 cyc for Q @ 5 x PU	
Delay time:	0.000 - 60 sec	
Time Accuracy:	±0.5% or ±½ cyc for P and N ±0.5% or ±1 cyc for Q	

TIME OVERCURRENT (51P, 51N, 51Q)

Pickup:	5A CT	0.5 - 16.0A
	1A CT	0.1 - 3.20A

Time dial: TD=K=0 - 99 for 46 curve
TD=0.0 - 9.9 for all other curves

Time-Current Characteristics:

The following expression describes the inverse time current characteristic for each curve:

$$T_T = \frac{AD}{M^N - C} + BD + K = \text{Time to trip}$$

$$T_R = \frac{RD}{M^2 - 1} = \text{Time for decaying reset}$$

where D = Time dial, M = Multiple of PU and A, B, C, N, K and R are constants that govern the shape of each curve. The protection engineer can set the constants for the P (programmable) curve to achieve virtually any characteristic.

CURRENT PICKUP ACCURACY (All 50 and 51)

Phase and Ground:	5A	2% or 50mA
	1A	2% or 10mA
Neutral and Negative Sequence:	5A	3% or 75mA
	1A	3% or 75mA

BREAKER FAILURE (BF)

Time:		50 - 999mSec
Dropout:	5A CT	0.5A
	1A CT	0.1A
Time Accuracy:	±0.5% or +1¼ cyc / - ½ cyc	

DIRECTIONAL CONTROL (ALL OVERCURRENT)

Mode:	Forward, Reverse, Nondirectional
67P Polarization:	Positive Sequence w/Memory Negative Sequence
67Q Polarization:	Negative Sequence
67N Polarization:	Selectable any combination Zero Sequence Voltage (Requires 4W VT) Zero Sequence Current (Requires IG) Negative Sequence

Curve Type	Constants					
	A	B	C	N	K	R
S1	0.2663	0.03393	1.000	1.2969	0.028	0.5000
S2	0.0286	0.02080	1.000	0.9844	0.028	0.0940
L1	5.6143	2.18592	1.000	1.000	0.028	15.750
L2	2.3955	0.00000	1.000	0.3125	0.028	7.8001
D	0.4797	0.21359	1.000	1.5625	0.028	0.8750
M	0.3022	0.12840	1.000	0.5000	0.028	1.7500
I1	8.9341	0.17966	1.000	2.0938	0.028	9.0000
I2	0.2747	0.1042	1.000	0.4375	0.028	0.8868
V1	5.4678	0.10814	1.000	2.0469	0.028	5.5000
V2	4.4309	0.0991	1.000	1.9531	0.028	5.8231
E1	7.7624	0.02758	1.000	2.0938	0.028	7.7500
E2	4.9883	0.0129	1.000	2.0469	0.028	4.7742
A	0.01414	0.00000	1.000	0.0200	0.028	2.0000
B	1.4636	0.00000	1.000	1.0469	0.028	3.2500
C	8.2506	0.00000	1.000	2.0469	0.028	8.0000
G	12.1212	0.00000	1.000	1.000	0.028	29.0000
F	0.0000	1.00000	0.000	0.0000	0.028	1.0000
46	*	0	0	2	0.028	100
P	0 to 600	0 to 25	0 to 1	0.5 to 2.5	0.028	0 to 30
T	User defined currents and time delays					

S1, S2 = CO Short Inv, IAC Short Inv A = IEC Standard Inverse
L1, L2 = CO Long Inv, IAC Long Inv B = IEC Very Inverse
D = CO Definite Time C = IEC Extremely Inverse
M = CO Moderately Inverse G = IEC Long Time Inverse
I1, I2 = CO Inverse, IAC Inverse F = Fixed Time
V1, V2 = CO Very Inv, IAC Very Inv 46 = Negative Sequence Overcurrent
E1, E2 = CO Ext Inverse, IAC Ext. Inverse P = Programmable
T = Table

* Constant A is variable for the 46 curve and is determined as necessary based on system full load current setting, minimum pickup, and K factor settings.

SYNC CHECK (25)

Delta Phase Angle:	1 - 99 degrees
Delta Voltage Magnitude:	1 - 20V
Delta Frequency:	0.01 - 0.50Hz
Phase Shift Compensation:	0 - 359 degrees

SYNC CHECK, VOLTAGE MONITOR (25VM)

Dead Threshold:	10 - 150V
Live Threshold:	10 - 150V
Dropout Time Delay:	0.050 - 60.0sec
Logic:	Dead Phase/Dead Aux. Dead Phase/Live Aux. Live Phase/Dead Aux.
Two Independent outputs:	25VM1 and 25VM2

PERFORMANCE SPECIFICATIONS, continued

PHASE OVER/UNDERVOLTAGE (27P, 59P)

Mode: 1 of 3; 2 of 3; 3 of 3
 Pickup: 10.0-300V_{L-L} or 10.0-300V_{L-N}
 Definite delay Time: 0.050 - 600sec.
 Inverse delay equations:
 For overvoltage protection $t(G) = \frac{TMS}{(G/G_s)} - 1$
 For undervoltage protection $t(G) = 1 - \frac{TMS}{(G/G_s)}$

where $t(G)$ =theoretical operating time with constant value of G (seconds); TMS =time multiplier setting; G =measured value of the characteristic quantity; and G_s =setting (pickup) value of the characteristic quantity.

NEGATIVE SEQUENCE OVERVOLTAGE (47)

Pickup: 1.0 - 300V_{L-N}
 Delay Time: 0.050 - 600 sec

AUXILIARY / 3V0 OVER/UNDERVOLTAGE (27X, 59X)

Mode: Fundamental V_x ,
 3rd Harmonic V_x
 3 phase Residual (3V0)
 Pickup: 1.0 - 150V
 Delay Time: 0.050 - 600 sec

POWER (32)

Mode: Forward, Reverse
 Pickup: 5A: 1.0-6000 Watts, 3 ph
 1A: 1.0-1200 Watts, 3 ph
 Pickup accuracy: $\pm 3\%$
 Delay time: 0.050-600 sec

FREQUENCY (81)

Mode: Over, Under
 Pickup: 20.00 - 70.00 Hz
 Delay Time: 0.000 - 600 sec
 Time Accuracy: $\pm 0.5\%$ or ± 1 cyc
 (Min. trip time affected by min. 3 cyc security count)
 Mode: Rate of Change (ROC)
 Pickup: 0.2 - 20Hz/sec
 Accuracy: 0.1 Hz/sec or 2%

GENERAL PURPOSE LOGIC TIMERS (62)

Mode: PU/DO
 1 Shot, Non-Retrig.
 1 Shot, Retrig.
 Integrating
 Latch
 T1 and T2 Delay Time: 0.000 - 9999 sec
 Time Accuracy: $\pm 0.5\%$ or $\pm 3/4$ cyc

RECLOSER (79)

Mode: Power up to close,
 Power up to lockout
 Reclose Shots: 0 - 4
 Reclose, Reset, Fail,
 Max. Cycle Timers: 0.100 - 600 sec
 Time Accuracy: $\pm 0.5\%$ or
 $+1\frac{3}{4}$ cyc/-0 cyc

VOLTAGE PICKUP ACCURACY (All 27, 47 and 59)

Phase (V_{L-L} or V_{L-N}): $\pm 2\%$ or $\pm 0.5V$
 Phase 3V0 and V2: $\pm 2\%$ or $\pm 0.5V$

DEFINITE TIME ACCURACY UNLESS OTHERWISE STATED (All 27, 47 and 59)

Definite Time Accuracy: $\pm 0.5\%$ or ± 1 cyc

SETTING GROUPS

Setting Groups: 4
 Control Modes: Automatic: CLP
 Recloser shot
 Dynamic load or unbalance
 External: Discrete input logic
 Binary: Input Logic

METERING

Current Range: 5A 0.5 to 15.0
 1A 0.1 to 3.0
 Current Accuracy: $\pm 1\%$
 Phase Voltage Range: 3W 0 - 300 V_{L-L}
 4W 0 - 300 V_{L-L}
 Phase Voltage Accuracy: $\pm 0.5\%$ for
 $50V < V_{L-L} < 300V$
 Watt/VAR: 5A 0 to ± 7500
 1A 0 to ± 1500
 Watt Accuracy: 1% @ Unity PF
 VAR Accuracy: 1% @ Zero PF
 Energy: 0 to $\pm 1.0E12$
 (F/R registers)
 Frequency: 10 - 75Hz
 Frequency Accuracy: 0.01Hz

DEMANDS (IA, IB, IC, IN, IQ, Fwd Watts, Rvs Watts, Fwd VARs, Rvs VARs)

Demand Interval: 1 - 60 min
 Demand Mode: Thermal

BREAKER MONITORING

Duty Mode: I or I²
 Duty Alarm Range: 0 - to 100%
 Op Counter Alarm Range: 0 - 99999
 Trip Time Alarm Range: 20 - 1000msec

NOTES

NOTES

ORDERING

SAMPLE STYLE NUMBER

The style number identification chart defines the electrical characteristics and operation features included in BE1-11 relays. For example, if the style number were BE1-11 **F5A1M2H2E00**, the device would have the following:

BE1-11

- (F) - Feeder Application
- (5) - 5 Amp Phase nominal current
- (A) - 5 Amp Neutral nominal current
- (1) - 48/125 Vac/Vdc power supply
- (M) - Modbus protocol
- (2) - Modbus/TCP with BESTNetPlus
- (H) - Half Rack Case
- (2) - Normally Closed Alarm
- (X) -
- (0) -
- (00) - Latest release of firmware

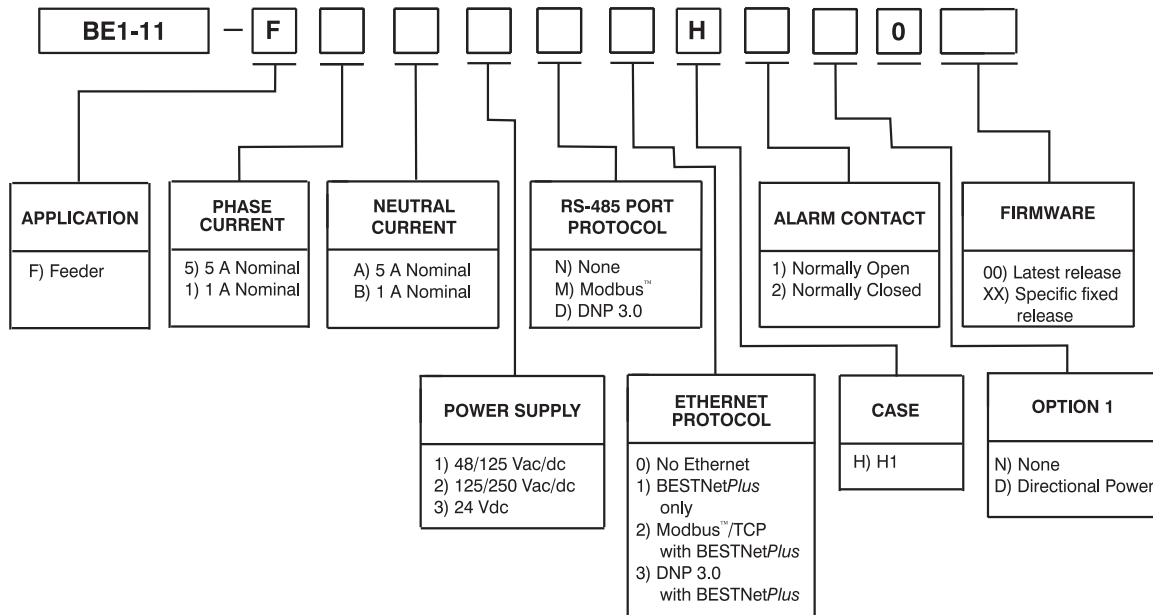

STANDARD ACCESSORIES

9289900017

Escutcheon plate to panel mount one H1 relay.

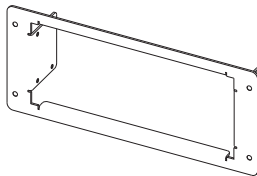

9289929100

Adapter bracket with cutout for ABB FT test switch, to mount a single H1 case in a 19" rack.

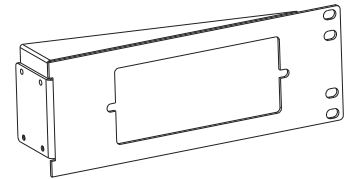

9289900016

Escutcheon plate to panel mount two dovetailed H1 relays.

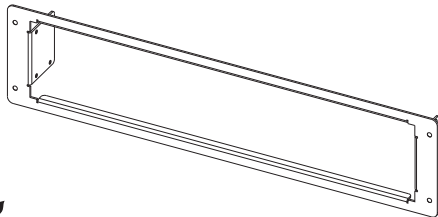

9289924100

Adapter bracket to mount single H1 case in 19" rack.

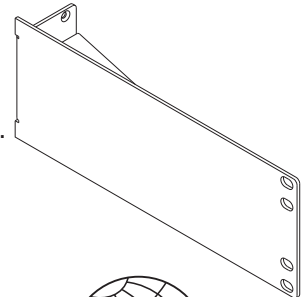

Basler Electric



P.A.E. Les Pins, 67319 Wasselonne Cedex FRANCE
Tel +33 3.88.87.1010 Fax +33 3.88.87.0808
e-mail: beifrance@basler.com

Route 143, Box 269, Highland, Illinois U.S.A. 62249
Tel +1 618.654.2341 Fax +1 618.654.2351
e-mail: info@basler.com

No. 1300 North Zhongshan Road, Wujiang Economic Development Zone
Suzhou, Jiangsu Province - P.R. China 215200
Tel +86(0)512 6346 1730 Fax +86(0)512 6346 1760
e-mail: beichina@basler.com

www.basler.com

Printed in U.S.A.